



Phone 800-374-7522

Fax 704-944-1918

www.enginepowersource.com

TECHNICAL MANUAL

SMART

START

Engine Control System

***VERY
IMPORTANT!***

**BEFORE DOING ANY WORK
ON THE SMART START PANEL OR ON
THE ENGINE-GENERATOR SET,
DISCONNECT THE POSITIVE (+)
BATTERY CABLE!**

GENERAL DESCRIPTION

The Smart Start Engine Control System is a microprocessor based control system consisting of:

ENGINE CONTROL PANEL

The Engine Control Panel houses the Engine Control Board, Engine Key Switch, optional Low Coolant Sensor Module and Mechanical Hour Meter.

The Engine Control Board is the heart of the system – it controls the Engine Glow Plugs, Starter and various engine Loads via its on-board mechanical relays. The Engine Control Board also reads various sensors on the engine and communicates information to the Remote Panel. LED lamps on this board are used to indicate various functions and any faults that may be detected.

The Engine Key Switch is normally placed in the “AUTO-START & RUN” position to apply power to the Engine Control Board and allow auto-starting from the Remote Panel. However, the Engine Key Switch can also directly control the Glow Plugs and Starter, and when the engine is started using this key switch, the micro-processor electronics on the Engine Control Board are effectively by-passed. Engine Loads and shutdowns are then controlled by a secondary mechanical relay located on the Engine Control Board. In essence, the Engine Key Switch serves as a back-up starting system to the Smart Start System. See the “BY-PASS STARTING AND STOPPING” section for additional details on this topic. When switched to the “OFF” position, power is removed from the Engine Control Board, Low Coolant Sensor Module, Remote Panel and the Mechanical Hour Meter.

The Low Coolant Sensor Module contains the electronics necessary to sense low coolant levels in the radiator. See the “LOW COOLANT SENSOR” section for details regarding the operation of this sensor.

REMOTE PANEL

The Remote Panel connects to the Engine Control Panel via a 4-wire shielded cable. This panel allows remote starting and stopping of the engine as well as monitoring of the engine’s basic operating functions. The Remote Panel features an extended temperature range, high contrast LCD display and LED indicator lamps.

TABLE 1: ELECTRICAL CHARACTERISTICS

ELECTRICAL CHARACTERISTICS	MINIMUM	TYPICAL	MAXIMUM
Standard Supply Voltage	7.0 V	12.0 V	15.0 V
Optional Supply Voltage (available upon request)	16.0 V	24.0 V	30.0 V
Shutdown Current (Engine Key Switch in "OFF" position)	---	0 mA	---
Stand-by Current (Engine Key Switch in "AUTO-START & RUN" position)	31.0 mA	34.0 mA	41.5 mA
Glow Plug Relay Current (intermittent)	--	--	50 A
Starter Solenoid Relay Current (intermittent)	--	--	30 A
Engine Load Relay Current (continuous)	--	--	15 A
Auxiliary Relay Current (avail. upon request)	--	--	15 A
Smart Start Operating Temperature Range	-20 C	--	+80 C
Remote Panel Operating Temperature Range	-20 C	--	+70 C

Smart Start System - Basic Functions

ENGINE STARTING & STOPPING

The Smart Start Engine Control System is designed to automatically perform all of the necessary steps to start and run the engine.

Remote Panel Auto-Starting and Stopping:

To start the engine from the Remote Panel, the Engine Key Switch must first be switched to the "AUTO-START & RUN" position to enable remote auto-starting. To begin the start sequence from the Remote Panel, momentarily depress the rocker switch to "START". The Smart Start System will immediately begin the sequence of events to start the engine and messages will appear on the Remote Panel display advising you of the progress and actions being taken. The start sequence can be interrupted at any time by depressing the Rocker Switch to "STOP" – or by switching the Engine Key Switch on the Engine Control Panel to "OFF". Should the engine fail to auto-start on the first attempt, the Smart Start System will wait approximately 30 seconds before attempting to start the engine again. Typically, the Smart Start System is programmed to try 3 times – but this feature can be turned off or extended to up to 9 times by the factory. Once started, the engine can be stopped at any time by pushing the Rocker Switch to "STOP" – or by switching the Engine Key Switch on the Engine Control Panel to "OFF".

If the Engine Key Switch on the Engine Control Panel is in the "OFF" position, power is removed from the Remote Panel, and nothing will happen when the rocker switch is depressed!

NOTE: Some Remote Panels are fitted with an optional Key Switch which must be switched to the "UNLOCKED" position to enable Remote Panel Starting. The engine can be stopped by depressing the Rocker Switch to "STOP" regardless of the optional Key Switch's position – only the starting function is controlled by the optional Key Switch.

Auxiliary Remote Starting:

A pair of Remote Start Contacts are provided to allow connection of the Smart Start System to a simple Remote Start Toggle Switch, Automatic Transfer Switch or to a DC Inverter equipped with a "Start" Relay. The Engine Key Switch must be in the "AUTO-START & RUN" position to enable remote starting via the Aux. Remote Starting Contacts. When the Aux. Remote Start Contacts are closed, the Smart Start System will begin the sequence of events required to start the engine. Opening the contacts at any time will interrupt the start sequence. Once started, the engine can be stopped by opening the Auxiliary Remote Start Contacts, switching the Engine Key Switch to "OFF", or by depressing the Rocker Switch on the Remote Panel to "STOP". Please see the Section on "Aux. Remote Start Contacts" for additional information and connection examples.

NOTE: In both cases above, if the engine has been auto-started (or attempted to be auto-started) within the last 30 seconds, a short delay will be engaged to prevent overheating of the engine starter and fuel solenoid.

By-Pass Starting and Stopping:

The Engine Key Switch on the Engine Control Panel should only be used to start the engine in the event that a malfunction prevents normal auto-starting from the Remote Panel – it is only there to act as a back-up system. To start the engine using the Engine Key Switch, use the following procedure:

Starting:

- 1) Pre-heat the engine with the glow plugs first, by turning the Engine Key Switch fully counter-clockwise to the “BY-PASS PREHEAT” position for 10 to 12 seconds. Do not preheat longer than 12 seconds as it is not necessary and may damage or reduce the life of the glow plugs.
- 2) After Pre-heating, turn the Engine Key Switch fully clock-wise to the “BY-PASS START” position to actuate the starter. The engine should start within 7 seconds. Allow about 30 seconds between cranking attempts to prevent over-heating the starter. When the engine starts, let off of the Key Switch and allow it to drop back into the “AUTO-START & RUN” position.

Stopping:

When the engine has been started from the Engine Key Switch, the “MANUAL BY-PASS” lamp will light up ‘green’ on the face of the Engine Control Panel. ***When the “MANUAL BY-PASS” lamp is lit, the engine can only be stopped by switching the Engine Key Switch to the “OFF” position.*** Although the Remote Panel may still operate, it has no control over the engine.

When by-pass started from the Engine Key Switch, only the Low Oil and Over-Temperature shutdowns are active. Rather than reading sending units when by-passed, (as is normally done by the Smart Start System), these two shutdowns use *additional* switched sending units to accomplish the shutdowns. All other shutdowns and faults are by-passed – including Low Coolant sensing.

ENGINE MONITORING SYSTEM:

While the engine is running or being auto-started, the Smart Start System continuously monitors the engine’s operating parameters. Should the engine begin to operate outside of *typical operating levels*, a “Warning” will be issued. If the condition is outside of *allowable limits*, the engine will be shut down to prevent damage and a “Fault” will be indicated.

Warnings and Faults are indicated in two ways:

Engine Control Board Warning/Fault Indicator Lamps:

Faults and warnings are indicated on the Engine Panel via LED indicator lamps. These lamps will indicate a warning via a “flashing code” sequence. Shutdown Faults are indicated in a similar manner. Refer to Table 2 for a detailed description of Flash Codes.

Remote Panel Messages:

Warning messages and a flashing red indicator LED are used to indicate warnings via the Remote Panel. In the event of a shutdown fault, the Warning LED will glow continuously and a description of the shutdown fault will scroll continuously on the display. The remote panel can be reset, and the fault “cleared”, by depressing the Rocker Switch to “STOP”.

Refer to Table 3 for a list of parameters that are typically monitored by the Engine Control Board. Warnings or Shutdown Faults are issued accordingly.

TABLE 2: FLASH CODES

Fault Description	Warning Code	Shutdown Code
Low Oil Pressure	Oil Pressure LED - One Blink	Oil Pressure LED - Lit
Oil Sender Failure	Oil Pressure LED - Two Blinks	N/A
High Coolant Temperature	Temperature LED - One Blink	Temperature LED - Lit
Temperature Sender Failure	Temperature LED - Two Blinks	N/A
Alternator Failure	Charging System LED - One Blink	N/A
High Voltage Warning	Charging System LED - Two Blinks	N/A
Low Voltage Warning	Charging System LED - Three Blinks	N/A
Low Coolant Level	N/A	Coolant Level LED - Lit
Under-Speed Shutdown	N/A	Over/Under Speed LED - One Blink
Over-Speed Shutdown	N/A	Over/Under Speed LED - Two Blinks
Engine Stalled	N/A	Over/Under Speed LED - Lit
Aux. Input Warning (opt.)	Glow Plugs LED - One Blink	N/A
Aux. Input Shutdown (opt.)	N/A	Glow Plugs LED - Lit
Over-Crank Failure	N/A	Engine LED - Two Blinks
Speed Sensor Failure	N/A	Engine LED - Three Blinks
Speed Sensor Failure (start)	N/A	Engine LED - Five Blinks
Engine Stalled	N/A	Over/Under Speed LED - Lit

N/A = Not Applicable

TABLE 3: ENGINE MONITORING

MONITORED PARAMETER	WARNING	SHUTDOWN
Oil Pressure	Yes	Yes
Coolant Temperature	Yes	Yes
Engine RPM's (Over & Under-speed)	No	Yes
Coolant Level (OPTIONAL)	No	Yes
Battery Voltage	Yes	No
Charging System	Yes	No
Over-crank (Engine failed to start)	No	Yes
Speed Sensor Operation	No	Yes
Coolant Temperature Sensor Operation	Yes	No
Oil Pressure Sensor Operation	Yes	No
Auxiliary Input(s) (OPTIONAL)	(Yes)	(Yes)

FAULT CODES:

The Smart Start System keeps track of any recent warnings or faults via ‘Fault Codes’ – which are stored in memory. These fault codes, as well as other running information can be downloaded from the Engine Control Board and displayed using the Remote Panel.

To view the stored fault information using the Remote Panel, switch the Engine Key Switch on the Engine Control Panel to the “AUTO-START & RUN” position, depress and hold the Remote Panel Rocker Switch in the “STOP” position (you will get an “Engine is Shutdown!” message). After about 7 – 10 seconds a “Downloading Memory” message will appear on the display – you may release the button at this time and wait for the download to complete. When the download is completed, the first screen of many will be displayed. To scroll through each screen, depress the Rocker Switch momentarily to “STOP”.

Typically, the first few screens contain information regarding the particular model as well as an “800” number from which to obtain service help. The engine Serial Number will also be displayed – have this number handy if you need to call for help, so that the Service Technician can access information regarding your unit.

Following the Serial Number Screen, The Problem Type History will be displayed. Problem Types & Warning Types are expressed as a complex number which can be used by EPS Service personnel to determine exactly which faults and warnings were being detected at the time the unit was shut down.

The next four screens contain the Fault Codes (listed as “Shutdown History”). The Smart Start System is capable of remembering the last 31 Fault Codes. The Codes are displayed in “Last-in First-out” order – that is to say that the last code to occur will be shown first, followed by the previous codes. Table 4 contains a full listing of the Fault Codes as well as descriptions and possible causes.

Following the Shutdown History, the next 8 screens display information logged from the *last* shutdown. This information includes Oil Pressure, Coolant Temperature, Battery Voltage, and Engine RPM’s. The Problem Magnitude, Problem Type and Action Code (i.e. Fault Code) from the last shutdown is also displayed.

The “Problem Magnitude” is an expression of the seriousness of the last shutdown. Fault magnitudes are categorized into four basic levels:

- “0” = normal shutdown by user
- “1” = warning pending when shutdown by user
- “2” = auto shutdown activated due to fault
- “3” = auto shutdown activated due to *multiple* faults.

The “Problem Type” is a complex numerical expression of exactly what faults and warnings were occurring when the unit was shut down.

The “Action Code” essentially represents the last action taken by the Smart Start System (generally this is the Fault Code).

All of this information is valuable to a Service Technician for getting to the root of a problem.

When trying to diagnose a problem, it is important to download all of this information and write it down immediately after the Shutdown or Warning Fault occurs. Otherwise, the Last Shutdown Data may be lost.

Pressing the Rocker Switch again will return the Remote Panel to its normal operating mode (“READY!” should appear on the screen).

Table 4: Fault Codes

CODE	DESCRIPTION	POSSIBLE CAUSES
O	Low Oil Pressure Shutdown	<ul style="list-style-type: none"> • Low oil level in crankcase • Oil filter needs to be replaced • An incompatible Oil Filter has been substituted resulting in low pressure.
P	Low Oil Pressure Warning	<ul style="list-style-type: none"> • Oil pressure sender wire is damaged (grounded out) • Major engine damage
p	Oil Pressure Sender Failure Warning	<ul style="list-style-type: none"> • Oil pressure sender has failed • Oil pressure sender wire is damaged (broken or loose)
H	High Coolant Temperature Shutdown	<ul style="list-style-type: none"> • Radiator fins are plugged with dirt or debris. • Inadequate airflow through radiator • Hot air re-circulating through radiator • Low coolant level or coolant leak • Broken fan belt or failed water pump
K	High Coolant Temperature Warning	<ul style="list-style-type: none"> • Temperature sender is damaged or faulty • Improper anti-freeze mixture • Leaky radiator cap • Temperature sender wire is damaged (grounded out)
h	Temperature Sender Failure Warning	<ul style="list-style-type: none"> • Temperature sender has failed • Temperature sender wire is damaged (broken or loose)
C	Low Coolant Level Shutdown	<ul style="list-style-type: none"> • Low coolant level or coolant leak • Air pocket in cooling system – vent air from radiator. • Low Coolant Module or Probe malfunction.
Z	Engine Stalled	<ul style="list-style-type: none"> • Ran out of fuel • Air bubble or leak in fuel supply system – vent air and check for possible leaks between tank and fuel pump. • Severe overload
U	Under-Speed Shutdown	<ul style="list-style-type: none"> • Sustained overload • Governor out of adjustment or damaged • Air cleaner filter needs to be replaced • Fuel filter needs to be replaced • Inadequate fuel supply – engine is stumbling
u	Low Cranking Speed Shutdown	<ul style="list-style-type: none"> • Low battery voltage • Mechanical load on engine while starting • Inadequate battery, or battery cables too small. • Loose or corroded battery cables.
F	Over-Speed Shutdown	<ul style="list-style-type: none"> • Governor out of adjustment or damaged

CODE	DESCRIPTION	POSSIBLE CAUSES
q	Speed Sensor Failure while Starting (Shutdown)	<ul style="list-style-type: none"> • Failed or damaged alternator • Broken or loose alternator belt • Speed sensor wire damaged (loose, grounding out or broken)
A	Alternator Failure Warning	<ul style="list-style-type: none"> • Failed or damaged alternator • Wiring to alternator is damaged • Dead or weak battery (shorted cell) • Plug to alternator is damaged or loose
a	Alternator/Alternator Wiring Failure	<ul style="list-style-type: none"> • Wiring to alternator is damaged • Plug to alternator is damaged or loose
B	Low Battery Voltage Warning	<ul style="list-style-type: none"> • Dead or weak battery
b	Low Voltage Reset (when starting)	<ul style="list-style-type: none"> • Dead or weak battery. • Battery undersized (<1000 CCA). • Loose or corroded battery cables. • Battery Cables too small or too long. • Loose, damaged or corroded ground connection – check all ground connections in harness. <p>⇒ See “LOW BATTERY PROTECTION” section below</p>
V	High Battery Voltage Warning	<ul style="list-style-type: none"> • Alternator failure • Field wire to alternator is damaged or loose
E	Over-Crank (Shutdown)	<ul style="list-style-type: none"> • Engine failed to start • Out of fuel or fuel supply problem • Blown Load Fuse (fuse-holder located below Engine Panel on harness) • Fuel Stop Solenoid Failure • Fuel Stop Solenoid Bracket damaged – preventing solenoid from bottoming out. • Glow plug failure • Plugged air cleaner
1 thru 9	Failed Auto-start Attempt	<ul style="list-style-type: none"> • Engine failed to start - the number corresponds to the attempt <p>⇒ See “LOW BATTERY PROTECTION”</p>
R	Shutdown via Remote Panel	<ul style="list-style-type: none"> • The “STOP” button on the remote panel was pushed
L	Shutdown via Engine Key Switch	<ul style="list-style-type: none"> • The master key switch was switched to “OFF”
I	Shutdown via Auxiliary Start Inputs	<ul style="list-style-type: none"> • Originally started via aux. start contacts and stopped via the aux. start contacts
X	Aux. Input Shutdown	(OPTIONAL EQUIPMENT)
W	Aux. Input Warning	(OPTIONAL EQUIPMENT)
\$	Engine started by Engine Key Switch (Smart Start Bypassed)	<ul style="list-style-type: none"> • indicates that the Smart Start System was bypassed.

LOW BATTERY PROTECTION:

If the voltage drops below about 6.5 volts during starting, the Smart Start will instantly abort the start attempt and reset itself. This can be detected by seeing the lights on the Engine Control Panel “race” up and down, immediately following an aborted start attempt. A “b” Fault Code is also placed in memory to signal that a Low Voltage Reset was triggered by a severe drop in voltage. Test the battery for charge, and if possible, check the electrolyte level in each cell. Check the battery connections and cables *carefully* – corroded terminals can cause a severe voltage drop during starting. Check the ground connections between the battery and the engine and the Engine Control Panel and the engine – loose or poorly grounded connections can cause severe voltage drops. It is okay to jump-start an engine equipped with Smart Start, but the jump-start source must be of the same system voltage as the Smart Start engine. Jump-starting with higher levels of voltage (i.e. forklift trucks, golf carts, etc) will damage the system.

Improper Battery and Cable sizing can also lead to severe voltage drops – particularly on cold days when starting amps are highest and battery performance is at its lowest level. To avoid voltage drop problems, refer to the table below for *minimum* recommendations.

BATTERY & CABLE SIZING

Engine Series	Minimum Battery CCA & Sizes	Minimum Cable Sizing
Kubota –05 Series	750 CCA Group 27	#2 < 10' #1 < 15'
Kubota –03 Series	1000 CCA Group 31	#2 < 6' #1 < 10'
Kubota V3300/3300T	1000 CCA Group 31 or 4D	#1 < 5' #1/0 < 9'
Cummins 4BT Series	1000 CCA Group 31	#2 < 5' #1 < 9'

REVERSED BATTERY PROTECTION:

The Smart Start Engine Controls are protected against the battery being connected backwards. In the event that the battery is connected backwards, the Engine Control Panel and Remote Panel will not operate. The “MANUAL BYPASS” Light on the Engine Control Panel will glow ‘red’ to indicate a reversed battery condition. **WARNING:** *Other* electrical parts on the engine (such as the alternator), may not be protected against a reverse battery!

OVER-TEMPERATURE PROTECTION:

The Remote Panel is also protected against over-temperature, and will shut itself off in the event that it becomes too hot. Since the Remote Panel generates very little heat and requires very little air circulation, over-heating can generally be attributed to an external source of heat or a hot environment. It is best to install the Remote Panel in an environment that does not exceed 70° C (160° F).

The power feed to the Remote Panel is also protected against over-temperature and will shut down the Remote Panel if the Engine Control Panel temperature exceeds 85° C (185° F). If the Engine Control Panel is reaching this temperature, something is very wrong and continued operation at or above this temperature may damage the unit.

LOAD PROTECTION FUSE

The Engine loads (fuel solenoid, fuel pump, alternator, etc.) are protected against over-load or short circuit by a 15A ATO Automotive fuse located directly below the Engine Control Panel on the Harness. In the event of an overload on one of the load circuits, this fuse will blow and power will be removed from all of the loads, shutting the engine down. When restarted, the engine will immediately stop – due to lack of power on the “hold” coil of the fuel solenoid. Typically, an “Over-crank” fault will result, due to repeated failures to auto-start.

IMPORTANT: In the event of a blown Load Protection Fuse, the source of the short circuit or over-load should be located and corrected *before* attempting to by-pass start the unit. The loads are not fuse protected when the unit is by-pass started! If there is a short circuit in the wiring or controls, and the engine is by-pass started, the Engine Control Board may be permanently damaged by the short circuit current!

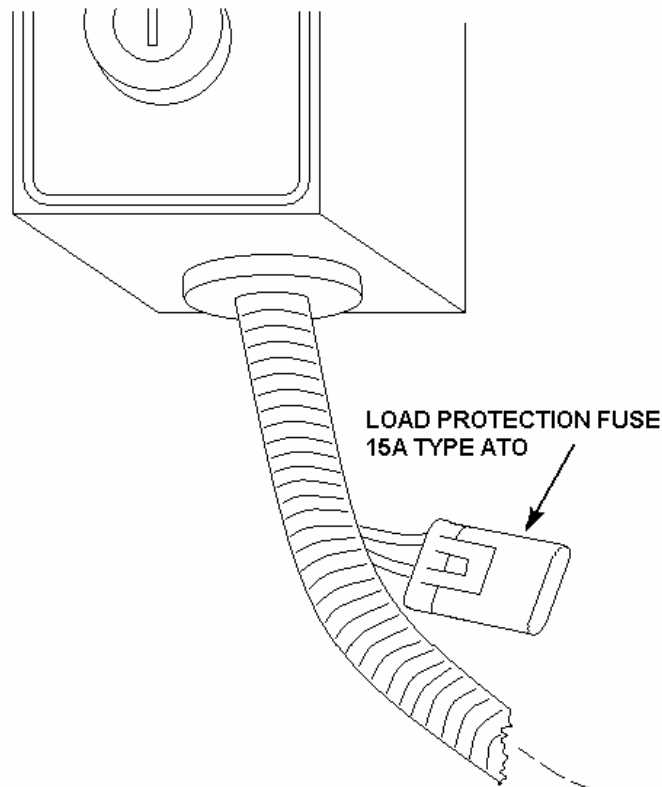

LOW COOLANT SHUTDOWN

Most Engine Control Panels are fitted with an optional Low Coolant Shutdown Module. In the event that a cooling system failure causes the system to rapidly lose coolant (i.e. a broken hose), the Low Coolant Sensor will shut the engine down before any damage is done. This sensor also shuts the engine down if radiator coolant levels drop to a point where engine cooling may become a problem.

How it Works

The Low Coolant Module works by measuring the resistance of the coolant in the radiator tank between the walls of the radiator tank and the tip of an insulated probe installed in the tank. The radiator is grounded using a separate black ground wire, and the insulated probe connects back to the Module using a separate wire (yellow/black-stripe).

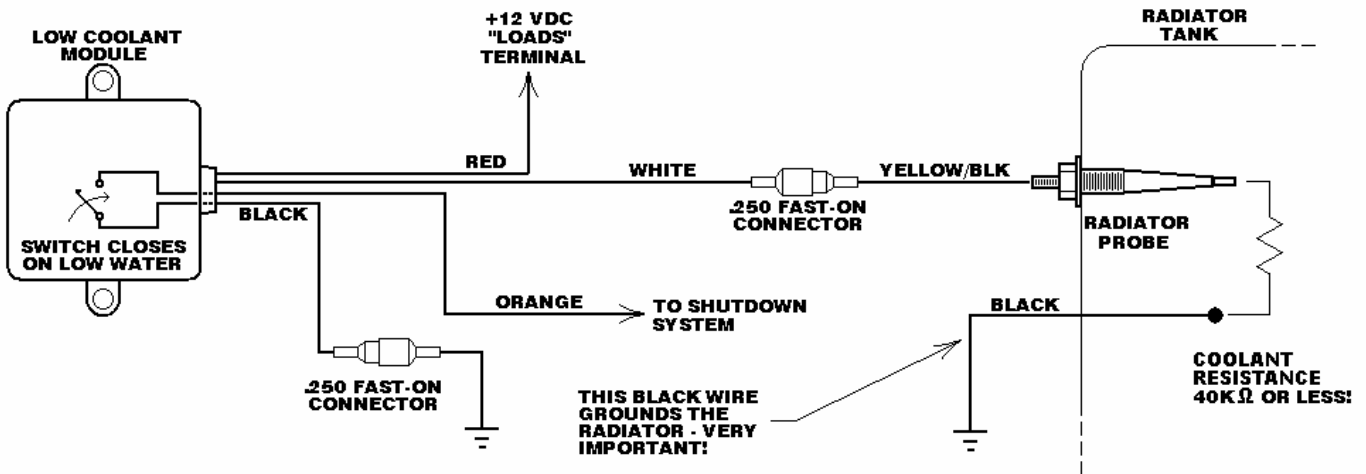

TYPICAL RESISTANCE-TYPE LOW COOLANT SYSTEM SCHEMATIC

Low Coolant Shutdown Causes

First, the obvious question – is the system really low on coolant? Allow the radiator to cool off before removing the cap – never remove a cap from a hot radiator! The coolant will immediately flash into steam and burn you!

Check the Coolant Overflow Bottle (if fitted with one). If it is empty, this is a good indicator that the radiator is low on coolant. As the radiator coolant heats up, it expands in volume. This “hot & expanded” coolant overflows from the radiator and is captured in the Overflow Bottle. As the radiator cools off, the fluid contracts back to its original volume and fluid is sucked back into the radiator from the Overflow Bottle. An empty Overflow Bottle on a hot radiator is a good indicator that the radiator is low on coolant.

Broken or Poor Radiator Ground:

Resistance-type Low Coolant Modules require that the radiator tanks be well grounded. Since most radiators are electrically isolated by rubber hoses and vibration mounts, it is necessary to run a separate ground wire directly to the radiator. Check the continuity of the grounding wire by measuring between the radiator tank metal and the engine block. Wiggle the ground wire around – particularly the ends – to assure that there are no intermittent connections or bad terminal crimps.

Trapped Air Pockets:

If the coolant has recently been low and refilled or it has been changed, air can become trapped in the cooling system. When the engine is run, it can accumulate around the sensor probe. Remote and Rear Mount radiator systems are particularly sensitive to this situation. It is important to open any air-bleed vents when adding or replacing coolant on these systems to clear the air out. Oftentimes, it takes several run and air-bleed cycles to clear the air out in severe cases. In many cases, trapped air can also form an air-lock that can prevent coolant from circulating properly through the radiator, leading to high temperature shutdowns.

Additives:

Some additives – particularly those used to seal leaks in the radiator – can cause intermittent problems due to the additive coating the probe tip and the inside of the radiator tanks. In essence it acts as an insulator, preventing the low coolant module from being able to measure continuity through the radiator. The coating is generally very, very thin and difficult to see with the naked eye. Disconnect the probe wire and use a good quality Ohm Meter to measure resistance between the probe and the tank. Most Resistance-type Low Coolant Modules require 40K Ohms or less to sense the coolant properly.

Low Conductivity Coolant:

Obviously, the coolant must have some conductivity for resistance-type Low Coolant Modules to detect. A 50/50 mixture of Polyethylene Glycol Coolant and tap water typically produce a good conductivity mixture. Using of distilled water will result in low conductivity mixtures which will result in shutdowns. “Extended Life” coolants have also been reported to result in low conductivity mixtures and is not recommended for use with Low Coolant Sensors. To measure conductivity, disconnect the probe wire and use a good quality Ohm Meter to measure resistance between the probe and the tank. Most Resistance-type Low Coolant Modules require 40K Ohms or less to sense the coolant properly. The addition of a small amount, (1/2 – 1 teaspoon), of baking soda to the coolant will often correct this problem. Repeated use of baking soda, however, is not recommended – there is simply no substitute for tap water and good old-fashioned Ethylene Glycol coolant!

Intermittent Sensor Wire:

Any kind of intermittency in the sensor probe wire on Resistance-type Low Coolant Modules will result in shutdowns. These can be fairly difficult to diagnose as they are typically intermittent in nature. Use a continuity meter to measure from one end of the wire to the other while wiggling and pulling on the connectors. If in doubt, add in a new wire to by-pass the existing one.

Grounded Shutdown Wire:

Should the shutdown wire insulation become damaged, it could ground out against metal, causing the unit to shutdown even though the module has not sensed a shutdown. Inspect this wire carefully – check for any indication of pinches, worn spots or melted areas that might lead to the wire grounding out.

Module Failure:

As with any electronic sensor, module failures are a possibility. Oftentimes they are intermittent and difficult to diagnose. Replacement of the module may be the best way to eliminate this possibility.

By-passing the Low Coolant Sensor

Naturally, before bypassing a low coolant shutdown system (or any sensor, for that matter), it is important to assure that the sensor is not detecting a legitimate problem – ie low coolant or an air pocket. Refer to the “Low Coolant Shutdown Causes” section (above) for detailed information on diagnosing Low Coolant Shutdowns.

Starting the engine from the Engine Control Panel (i.e. by-pass starting), will by-pass the Low Coolant Module.

The Low Coolant Sensor can be permanently bypassed by disconnecting the “shutdown wire” (orange) from the shutdown system. Sometimes, a quick and easy bypass method is to ground the probe wire. This is often used in the field to bypass the radiator probe and get things running again – however, if there is a severe module malfunction, or a loose or broken Probe or Shutdown wire, the unit may continue to shut down ... *the only certain way is to disconnect the orange Shutdown wire and insulate both bare ends.*

NOTE: Disconnecting the probe wire does not work – doing this will only assure that the Low Coolant Module shuts the engine down as it can no longer sense any continuity through the radiator coolant!

LOW OIL SHUTDOWN

The Oil Pressure Sending Unit used with the Smart Start system contains a resistive element *and* an auxiliary shutdown switch.

How it Works

When auto-started, using the Remote Display Panel, the Engine Control Board only uses the resistive element to determine oil pressure – the auxiliary switch is not used.

When by-pass started, using the key switch on the Engine Control Panel, the shutdown relay on the Engine Control Board only uses the auxiliary shutdown switch to shut the unit down. Although the circuitry on the Engine Control Board may still be monitoring the resistive element in the Sending Unit, it has no control over the engine shutdowns.

The Oil Pressure Sending Unit has two black screw-terminal knobs on top which make connection to the resistive element and auxiliary switch. Terminal markings are stamped into the metal body beside each terminal. The resistive element is marked “G” and the switch contact is marked “WK”.

The switch contact is designed to close to ground at 7 PSI and below, and to remain open at 7 PSI and above. The resistive element is designed to measure a pressure range of 0 – 80 PSI. At 0 PSI, the resistive element will measure roughly 10Ω. The resistance increases with pressure, to a maximum of 180Ω at 80 PSI. The resistance will increase roughly 21Ω with every 10 PSI increase in oil pressure. For example: 40 PSI would result in ... $(4 \times 21\Omega) + 10\Omega = 94\Omega$.

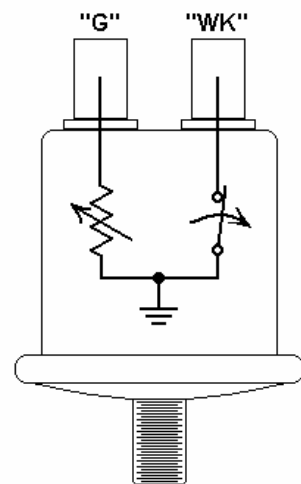

Low Oil Pressure Warning & Shutdown Causes

The Smart Start System is designed to warn of low oil pressures at 21 PSI and below and to automatically shut the engine down at 7 PSI and below. Low oil pressures can lead to severe damage to an engine, and should not be taken lightly.

Once again, check the obvious – is the engine low on oil? Is there any indication of a leak? Very low oil levels will result in low oil pressures, quickly leading to damage.

First thought is often to suspect a defective sender. However, before attempting to bypass an oil pressure sender, it is important to assure that the engine does indeed have adequate oil pressure. Temporarily replace the electrical sender with a mechanical oil pressure gauge. Inexpensive mechanical oil pressure gauges can be purchased at most auto parts stores, and are an invaluable tool for any mechanic to have.

When the engine is started and run with the mechanical gauge in place, oil pressure should rapidly build to roughly 40 PSI or higher. As the engine warms up, pressure should typically remain above 35 PSI. If the pressure is low or drops during the test, shut the engine down immediately – remember, you've disconnected the Low Oil Shutdown and you must carefully monitor the pressure to prevent damage should the pressure turn out to be low!

Replacement sending units can be obtained from Engine Power Source (P/N:360-009) or from NAPA Auto Parts (P/N: 701-1824).

NOTE: When replacing or re-installing the electrical sending unit, do not use Teflon tape to seal the threads – the threads must make good electrical contact to the engine block. Loctite 567 Thread Sealant is used with excellent results on production units.

If it turns out that the engine does have plenty of oil pressure, check for the following conditions which may result in sending unit malfunctions:

Defective Sending Unit:

Disconnect the Blue wire from the “G” terminal of the Sender. Using an Ohm Meter, measure the resistance of the “G” terminal to Engine Ground with the engine running. The resistance will typically run between 70 Ω and 110 Ω . Also, Disconnect the Gray/Red-stripe Wire and check continuity from the “WK” terminal to Engine Ground – the switch contacts should remain *open* while the engine is running. Inspect the Sending Unit carefully. A blocked orifice at the tip of the threaded end can cause incorrect readings as can dirt or water contamination.

Sending Unit Wire Shorted to Ground:

If one of the wires going to the unit is shorting out to any of the engine metal, it will result in inconsistent or low pressure readings. Careful inspection of the wiring harness will usually reveal any damaged areas. To test the wires directly, disconnect both wires from the sending unit and from the Engine Control Board and use an Ohm-meter to measure resistance between the wires and engine ground. The resistance should be infinite or *very high* (>10M Ω).

Intermittent Short Circuit to Ground:

Sometimes, when the insulation on a wire becomes damaged or is “pinched” between metal surfaces, it will make intermittent contact to the metal while the engine is running – but will not make contact when the engine is stopped. These “running shorts” can be very difficult to diagnose. Wiggling the wires and harness along its length will sometimes reveal an intermittent short circuit.

Sender Wires Reversed:

Assure that the Gray/Red-stripe Wire is connected to the “WK” terminal and the Blue wire is connected to the “G” terminal.

If it turns out that the engine really is producing low oil pressure, check for the following conditions which may result in low oil pressure:

Incorrect Oil Filter:

Although many different sizes and types oil filters can be found which will adapt to the engine, it is very important to use only approved or OEM oil filters. It is not uncommon for a “substitute” filter to restrict the flow of oil, causing low oil pressures and oil starvation.

Clogged or Faulty Oil Filter:

Replacing the Oil Filter will eliminate this possibility.

Other “Engine-related” Causes:

Some other possible causes for low oil pressure include: Blocked oil passages, worn bearing surfaces and a worn or damaged oil pump.

HIGH TEMPERATURE SHUTDOWN

The Temperature Sending Unit used with the Smart Start system contains a resistive element *and* an auxiliary shutdown switch.

How it Works

As with the Oil Pressure Sending Unit, when auto-started, the Engine Control Board only uses the resistive element to determine temperature – the auxiliary switch is not used. When by-pass started, the shutdown relay on the Engine Control Board only uses the auxiliary shutdown switch to shut the unit down.

The Temperature Sending Unit has two quick-connect terminals on top, which connect to the resistive element and auxiliary switch. Terminal markings are molded into the plastic body beside each terminal – but it is easier to tell them apart by the size of the terminals. The resistive element is connected to the larger of the two terminals, and the switch is connected to the smaller of the two.

The switch contact is designed to close to ground at 217°F and above, and to remain open at temperatures below 217°F. The resistive element is designed to measure a temperature range of 70°F – 250°F. At 75°F, the resistive element will measure roughly 600 Ω. The resistance decreases *non-linearly* with temperature. The resistance at 140°F is roughly 135 Ω, and the resistance at 195°F is roughly 50 Ω.

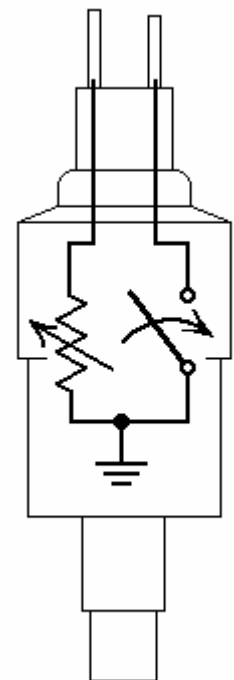

High Temperature Warning & Shutdown Causes

The Smart Start System is designed to warn of high temperature at temperatures above 220°F and to automatically shut the engine down at 225°F and above. When By-pass Started, the engine will shut down at a slightly lower temperature of 217°F. Excessive coolant temperatures can lead to severe engine damage, and should not be taken lightly.

As always, check the obvious – is the engine low on coolant? Is there any indication of a coolant leak? Is the ventilation system working properly (including any auxiliary fans)? Is the radiator plugged with dirt? All of these can lead to excessive temperatures.

When diagnosing over-temperature shutdowns, it is important to eliminate the possibility of a defective sender. Typically, a defective sending unit will shut a *cold* engine down within about 60 seconds of starting. However, before attempting to bypass a temperature sender, it is important to assure that the engine is not running hot. Temporarily replace the electrical sender with a mechanical temperature gauge. Inexpensive mechanical temperature gauges can be purchased at most auto parts stores, and as with the mechanical oil pressure gauge recommended above, are an invaluable tool for any toolbox.

Replacement sending units can be obtained from Engine Power Source (P/N:323-099).

NOTE: When replacing or re-installing the electrical sending unit, do not use Teflon tape to seal the threads – the threads must make good electrical contact to the engine block. Loctite 567 Thread Sealant is used with excellent results on production units.

If it turns out that the engine is not running hot, check for the following conditions which may result in sending unit malfunctions:

Defective Sending Unit:

Disconnect the Brown wire from the *larger* terminal of the Temperature Sender. Using an Ohm Meter, measure the resistance of the terminal to Engine Ground with the engine running at no-load. The resistance will typically run between 50 Ω and 75 Ω , once the engine is warmed up. Also, Disconnect the Gray/Red-stripe Wire and check continuity from the smaller terminal to Engine Ground – the switch contacts should remain *open* while the engine is running.

Sending Unit Wire Shorted to Ground:

If one of the wires going to the unit is shorting out to any of the engine metal, it will result in inconsistent or high temperature readings. Careful inspection of the wiring harness will usually reveal any damaged areas. To test the wires directly, disconnect both wires from the sending unit and from the Engine Control Board and use an Ohm-meter to measure resistance between the wires and engine ground. The resistance should be infinite or *very* high (>10M Ω).

Intermittent Short Circuit to Ground:

Sometimes, when the insulation on a wire becomes damaged or is “pinched” between metal surfaces, it will make intermittent contact to the metal while the engine is running – but will not make contact when the engine is stopped. These “running shorts” can be very difficult to diagnose. Wiggling the wires and harness along its length will sometimes reveal an intermittent short circuit.

If it turns out that the engine really is running hot, check for the following conditions which may result in over-temperature:

Dirty or Blocked Radiator:

Inspect the radiator fins carefully. Over time, radiators tend to accumulate dirt and debris which blocks the air flow through the radiator. The dirtier the environment, the less time it takes for the radiator fins to get loaded up with dirt. Use a garden hose with a spray nozzle to clean the dirt from the fins. Do not use a pressure washer – the high pressure from a pressure washer can literally tear the radiator fins and tubes apart!

Inadequate Ventilation:

The radiator and generator end need a continuous supply of cool air to work properly. Assure that all supplemental cooling fans are working properly. In some installations, it is possible for the hot air coming from the generator or radiator to be re-circulated back through the radiator, causing excessive temperatures. This will usually show up shortly after the generator is installed or on the first hot day after installation. Naturally, the only solution is to improve the air supply to the radiator. Contact EPS's Engineering Dept. for generator installation recommendations.

Air Pocket in Cooling System:

When the coolant is drained and changed in the cooling system, it is possible for an air pocket to form, which prevents the water pump from being able to pump coolant. Typically, this occurs most frequently on Remote-mount Radiator installations or on Rear-mount installations. Air Vents are typically supplied to allow venting the excess air from the system while it is being filled. Air Pockets can be very difficult to diagnose – since little or no coolant is flowing, the engine overheats very rapidly - which can lead one to believe that it is merely a defective sending unit. Often times, when the temperature sensor is removed and replaced, the air pocket is vented out, “accidentally” correcting the real problem, *and making you believe that it really was a defective sending unit.* After 2 or 3 sending units have been replaced over time, it will become apparent that something more sinister is at play... remember to vent the air when replacing coolant!

Other “Engine-related” Causes:

Some other possible causes for high engine temperature include: Failed or damaged Water Pump, loose belts, blockages inside of radiator or cooling system, and incorrect coolant mixtures (always use 50/50 coolant mixture).

SPEED SENSOR FAILURES

The Smart Start System uses the alternator as a speed sensor. An Orange/White-stripe Wire connects to one of the diodes on the alternator's regulator. This produces a "square wave" signal, directly proportional to the engine's speed.

Speed Sensor Failure Causes

The Smart Start System is designed to shut the unit down or abort the auto-start process in the event of a Speed Sensor failure. Starting the unit from the Engine Control Panel, effectively by-passes the Speed Sensor – as it is not used when in by-pass mode. Once By-pass Started, some simple checks can be made to determine the cause of the problem.

Broken or Loose Alternator Belt:

This is the most common cause for this failure. If the belt is broken, the alternator will not generate a speed signal. Loose belts will produce abnormally low or "unstable" readings which can also be interpreted as a Speed Sensor Failure.

Speed Sensor Wire Disconnected or Shorting to Ground:

Check the display – even when bypassed, the Smart Start will attempt to read the engine RPM's. If the RPM's are 0, then the speed sensor wire may be disconnected. Shut the engine down and inspect the harness. Check the connectors between the Engine Control Panel and the Engine Harness carefully. There is an in-line bullet connector on the Orange-White-stripe Speed Sensor Wire located inside of the Harness Loom about 6" from the Alternator. An Ohm Meter can be used to check continuity from one end to the other – just remember to disconnect the wire at both ends. Also check the Alternator Belt – a broken or loose alternator belt will show up as a Speed Sensor Failure.

Intermittent Speed Sensor Wire Connection:

If the display reads inconsistently when by-passed, there may be an intermittent connection issue or an intermittent short circuit to ground. Once again, use the "wiggle-the-wire" method to narrow down on the location of the loose connection.

Alternator Failure:

Needless to say, if all else checks out, the alternator may have failed – or may be on the verge of failing. Typically, the battery voltage will measure about 14.2V when an alternator operating properly, although this is not a sure-fire test of its operation. To measure the Speed Sensor signal directly, unplug the in-line bullet connector on the Orange-White-stripe Speed Sensor Wire (located about 6" from the Alternator). Using a Voltmeter set for DC volts, measure the voltage between this wire coming from the Alternator and Engine Ground. It should be approximately 50% of the Battery Voltage. The DC voltage should also stay very constant over time. If the voltage "wanders" around or is well below 50% of the Battery Voltage, the Alternator is likely malfunctioning and needs to be replaced.

Intermittent or Oxidized Field or Charging Wire Connection:

If the Field Power Wire connection (Orange Wire on White Connector) becomes intermittent or gets oxidized or corroded, the alternator will not charge properly and the speed sensor signal will become inconsistent. The same is true of the Charge Wire (Red 12G wire on charging stud). Oftentimes, there is a thin, almost invisible, coating of oxidation that has formed on the terminals due to dirt or road-salt, and

simply removing the terminals and cleaning them will resolve the problem. Be careful when loosening or tightening the Charge Wire as there is battery power on this terminal at all times! Always remove the Battery Positive (+) terminal before attempting to tighten or clean the Charge Wire Terminal.

Dirty Alternator Shorting out Signal:

Over time, dirt and grime can accumulate on the back of the diodes on the alternator regulator – where the speed is sensed. This dirt tends to “loads down” the speed signal to the point where it is difficult to read, resulting in a “wandering” RPM signal. Disconnect the Battery Positive (+) Cable. Remove the cover from the back of the alternator and wash down the regulator with soap and water using a scrub brush. Flush it out with clean water and dry everything out thoroughly before re-assembling the back cover and starting the unit. Allowed to go uncorrected, this condition can eventually lead to complete alternator failure.

ENGINE CONTROLLER MEMORY & SET-UPS:

The Smart Start System comes pre-programmed and configured from the factory. Several of the Engine Control Set-up Variables, as well as the general information recorded in memory, can be customized by the factory – or changed by the customer, using an EPS Hand-held Service Tool. Below is a list of the Engine Control Variables and General Memory along with the standard contents.

Table 4: Standard Memory Contents

Description	* Standard or Typical Contents
General Memory – Page 1, Line 1 (16 characters)	" ENGINE POWER "
General Memory – Page 1, Line 2 (16 characters)	" SOURCE "
General Memory – Page 2, Line 1 (16 characters)	" SMART START "
General Memory – Page 2, Line 2 (16 characters)	" V. 2.02 "
General Memory – Page 3, Line 1 (16 characters)	" FOR SALES "
General Memory – Page 3, Line 2 (16 characters)	" AND SERVICE "
General Memory – Page 4, Line 1 (16 characters)	" CALL EPS AT: "
General Memory – Page 4, Line 2 (16 characters)	" 1-800-374-7522 "
General Memory – Page 5, Line 1 (16 characters)	" SERIES 10020 "
Engine Serial Number – 6 characters	"XX1234"
Alternator Pulley Ratio (depends on engine model)	1.99 : 1
Alternator Pulses per Revolution	6
Over-Speed RPM Limit (Over-Speed Shutdown)	1950 RPM
Under-Speed RPM Limit (Under-Speed Shutdown)	1750 RPM
Low Oil Shutdown	7 PSI
Low Oil Warning	20 PSI
Coolant Temperature Shutdown	225
Coolant Temperature Warning	220
High Battery Voltage Warning	15.0 V
Low Battery Voltage Warning	12.2 V
Pre-Glow Time (Glow before starting)	10 seconds
Post-Glow Time (Glow while starting)	7 seconds
Starter Actuation Time (Cranking time)	7 seconds
Starter Disengagement RPM	1000 RPM
Minimum Acceptable Cranking RPM	100 RPM
Maximum Auto-start Attempts	3 attempts (up to 9 maximum)
Auto-start Attempt Interval (Time between attempts)	30 seconds
Auto-shutdown Delay (immediately following starting)	5 seconds
Low Charging Voltage Warning	12.7 V

* Typical EPS Series 10020 Generator configuration shown above, actual memory contents may vary depending upon make, model & options.

REMOTE PANEL CONNECTION

The Remote Panel is designed to be connected to the Smart Start Engine Control Panel via a 4-wire shielded cable. The cable mates to the Engine Control Panel via a short “pig-tail” with a sealed 5 pin circular connector located below the Engine Panel. A mating “C-Grid” connector is located on the Remote Panel circuit board, making installation and wire routing a snap. Pre-wired cables are available directly from the factory in standard (50 ft.) or custom lengths.

Figure 1: Connecting a Remote Panel

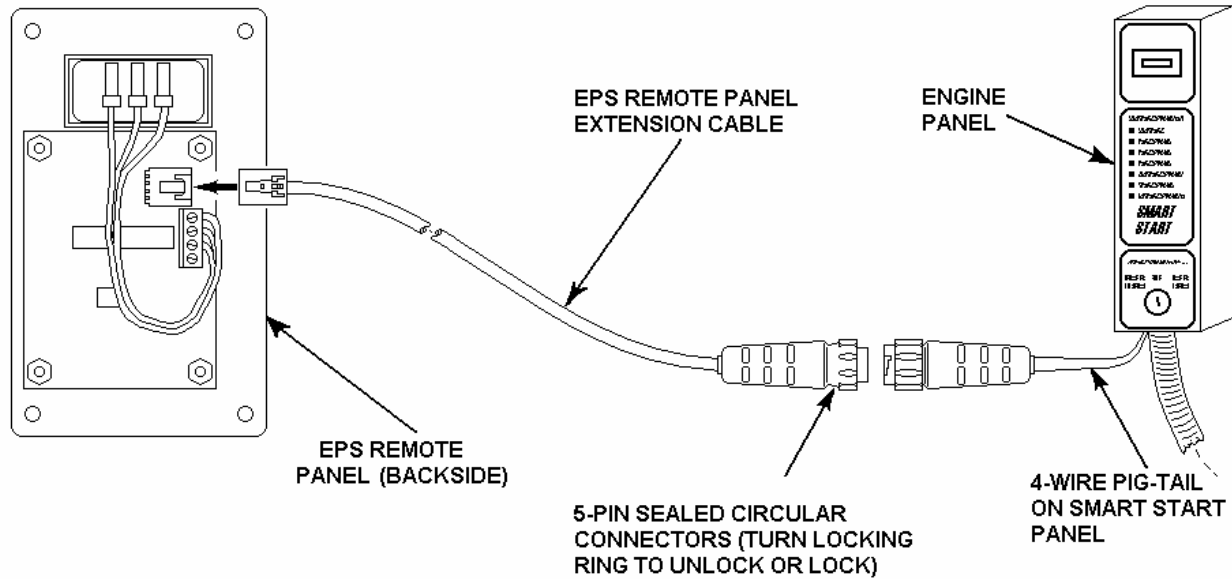

For best results, a small amount of Silicone Di-Electric Grease (NAPA 765-1190 or equiv.) should be smeared inside of the Sealed Connector on the Communication Cable to prevent moisture contamination and to lubricate the seal.

AUX. REMOTE START CONTACTS

A pair of Remote Start Contacts are provided to allow connection of the Smart Start System to a simple Remote Start Toggle Switch, Automatic Transfer Switch or to a DC Inverter equipped with a “Start” Relay. These contacts are sometimes referred to as “two wire start” contacts. Connection to the contacts is made via a short 2-wire “pig-tail” located below the Engine Panel. Closing the contacts together will cause the Smart Start system to auto-start and run. Opening the contacts will shut the engine down. The Master Keyswitch must be in the “REMOTE START” position to enable the Auxiliary Remote Starting.

Always include the 1A fuse shown in the diagram and assure that all connections are sealed and water-tight to prevent corrosion and contamination that could cause unreliable or unpredictable operation.

An example of a typical connection to a Trace™ “SW Series” DC Inverter is shown below. In this configuration, the Trace™ Inverter will automatically signal the Smart Start System to start the genset when the DC Battery Bank requires charging. Once the Battery Bank is recharged, the Trace™ Inverter will signal the Smart Start System to shut the Gen-set down.

Figure 2: Auto-starting from Trace Inverter

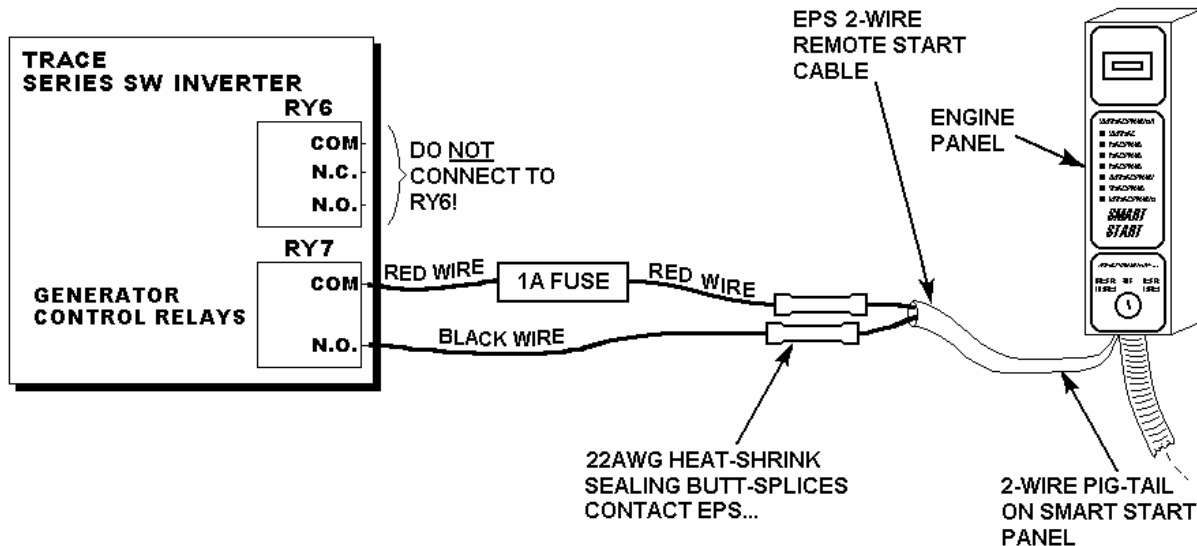

NOTE: The Inverter must be auto-start capable and programmed accordingly.

STANDARD OPTIONS

Standard Remote Panel

The Smart Start System is designed to be used with the Remote Panel. The Remote Panel allows simple connection to the Smart Start Engine Panel via a snap-together 4-wire Extension Cable. The Remote Panel allows the user to start, stop and monitor the engine from up to 100 feet away. Longer distances can be accomplished using special cables – contact EPS’s Engineering Department for details. Additionally, several options are available with the Remote Panels:

Remote Panel Key Switch

An Optional Key Switch can be added to the Remote Panel, which can be used by the customer to “lock-out” the “START” function of the Remote Panel. This is particularly useful in applications in which unauthorized personnel might tamper with the controls (such as Tour Coaches). The “STOP” function is typically not locked out; however, this function can also be locked out if required.

Instrument Panel Lighting Control

The Back-light on the LCD display can be programmed and configured upon request to be controlled directly by the Instrument Panel lighting circuit in the dashboard of a vehicle.

Additional Indicator Lights

In addition to the standard “ENGINE RUNNING” and “ALARM” LED indicator lights, two additional LED indicator lights can be added to the Remote Panel. These lights can be used to give visual indication of various functions, systems or alarms.

Custom Screens

The Remote Panel Microprocessor can be programmed by the factory to display custom or customer specified messages. Screen-size is 2 lines x 16 characters/line.

External Lamp Driver

The Remote Panel can also be configured to drive an external 12VDC lamp. The lamp driver can be programmed to “follow” any of the other indicators or to indicate an entirely separate function. Lamp current is normally limited to a maximum of 250 mA ($\frac{1}{4}$ A), but can be extended up to 1 A upon request. Remote Panels come standard with a 250 mA driver that follows the “ENGINE RUNNING” light.

Additional Switches

Additional switches or push-buttons can be added to the Remote Panel to facilitate custom functions. Contact EPS Engineering concerning this option.

Dash-mount Case with Speed Control

The Remote Panel is also available in an attractive all-metal enclosure for mounting below the dash of a truck or for use in any other *weather-protected* location. This panel is equipped with an additional Panel Key Switch, which can be used by the customer to “lock-out” the “START” function of the Remote Panel. Additionally, the Dash-Mount Control Panel can be produced with Electronic Speed Control, (also requires an electronic governor on the engine), for remote control and speed adjustment of a hydraulic power unit engine, pump engine, or industrial engine. Units equipped with Speed Control also feature a Scroll Lock button for freezing the display on a particular screen to allow continuous monitoring of a particular function. Contact the factory for details.

Optional Auxiliary Outputs

The Smart Start System can be specified to have additional Auxiliary Outputs for control of additional accessories. As many as 3 additional high power (15 A) relay outputs can be added to the Engine Control Board for direct control of loads or slave relays. Custom programming can be added to the microprocessor to control the output per the customer's specifications. Two additional low power outputs (1 A) can be added to the Remote Panel for control of low power accessories or high power accessories via slave relays. As with the Engine Control Board, custom programming can be added to the Remote Panel to accomplish control of these outputs. Contact Engine Power Source's Engineering Department for additional information regarding the Optional Auxiliary Outputs.

Optional Auxiliary Inputs

The Smart Start System can be specified to have up to 3 additional Auxiliary Inputs for monitoring sensors or switches. The Inputs can be configured and programmed as a "switched" input (i.e. "on" or "off") or as an analog input (as with a fuel gauge or temperature sensor). Custom programming can be added to the microprocessor to monitor the inputs per the customer's specifications. Two additional Auxiliary Inputs can be added to the Remote Panel as well. Contact Engine Power Source's Engineering Department for additional information regarding the Optional Auxiliary Inputs.

24V Configurations

The Smart Start System can be configured by the factory for 24VDC operation. Contact the factory for details.

***SMART
START
ELECTRICAL
DIAGRAMS***

REV	DATE	REVISION	BY
A	-	RELEASED FOR PRODUCTION	-
B	11/11/03	CHANGED TO ROUND 5-PIN PLUG	PSL
C	12/29/05	RAN BY-PASS LOADS THRU FUSE	PSL

- NOTES:
- 1) FUEL SOLENOID GROUND IS INTERNAL ON 40KW MODEL
 - 2) TAPS INTO ALTERNATOR
 - 3) RED 12G IS 10G ON 40KW MODEL

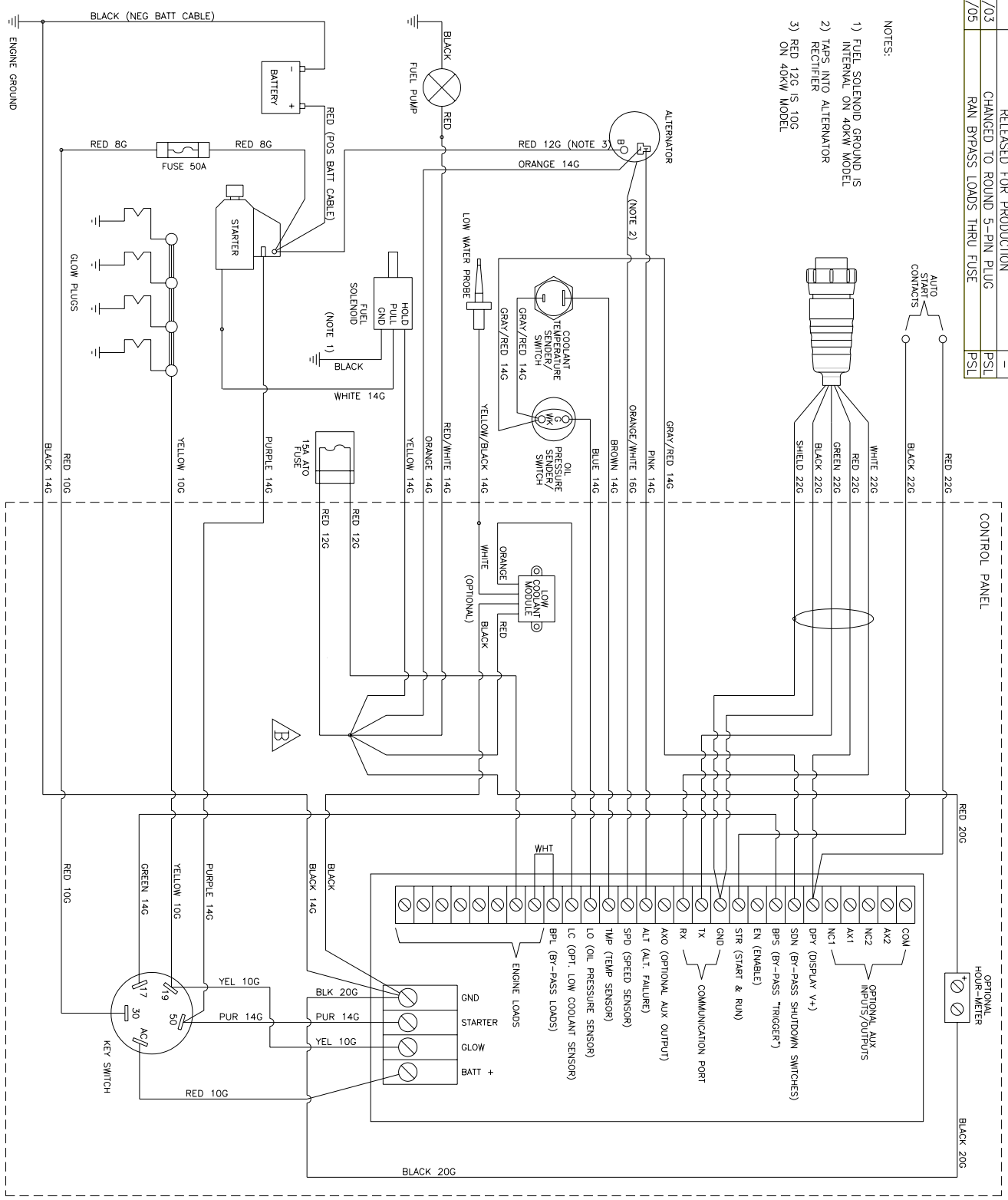

NO SCALE ACAD

This Document and all information contained in this document are confidential and proprietary to EPS. Unathorized possession or use thereof is prohibited. This document, or any part hereof, or any information contained herein, may not be duplicated, reproduced, or disclosed to any person for any purpose except as specifically authorized in writing by EPS. By accepting this document, recipient agrees to comply with the foregoing and to return this document to EPS immediately upon request. Unpublished - all rights reserved under copyright laws.

EPS	ENGINE POWER SOURCE	220 Olympic Street, Charlotte, NC 28273 Phone: 704-553-7286 Fax: 704-588-9719	CAD BY PSL	DATE 11/5/02	SHEET NUMBER 1 OF 1	UNSPECIFIED TOLERANCES ANGULAR.....1/2° FRACTION.....015 .XX.....010 .XXX.....005
PART NUMBER EPS2120	REVISION C	DESCRIPTION SCHEM, SER 100 SMART START	MATERIAL -	ADDITIVE FINISH -		

REV	DATE	REVISION	BY
A	-	RELEASED FOR PRODUCTION	-
B	11/11/03	CHANGED TO ROUND 5-PIN PLUG	PSL

VIEWED FROM
WIRE ENTRY
SIDE OF
CONNECTOR

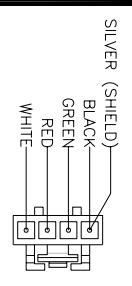

VIEWED FROM
FACE OF
CONNECTOR

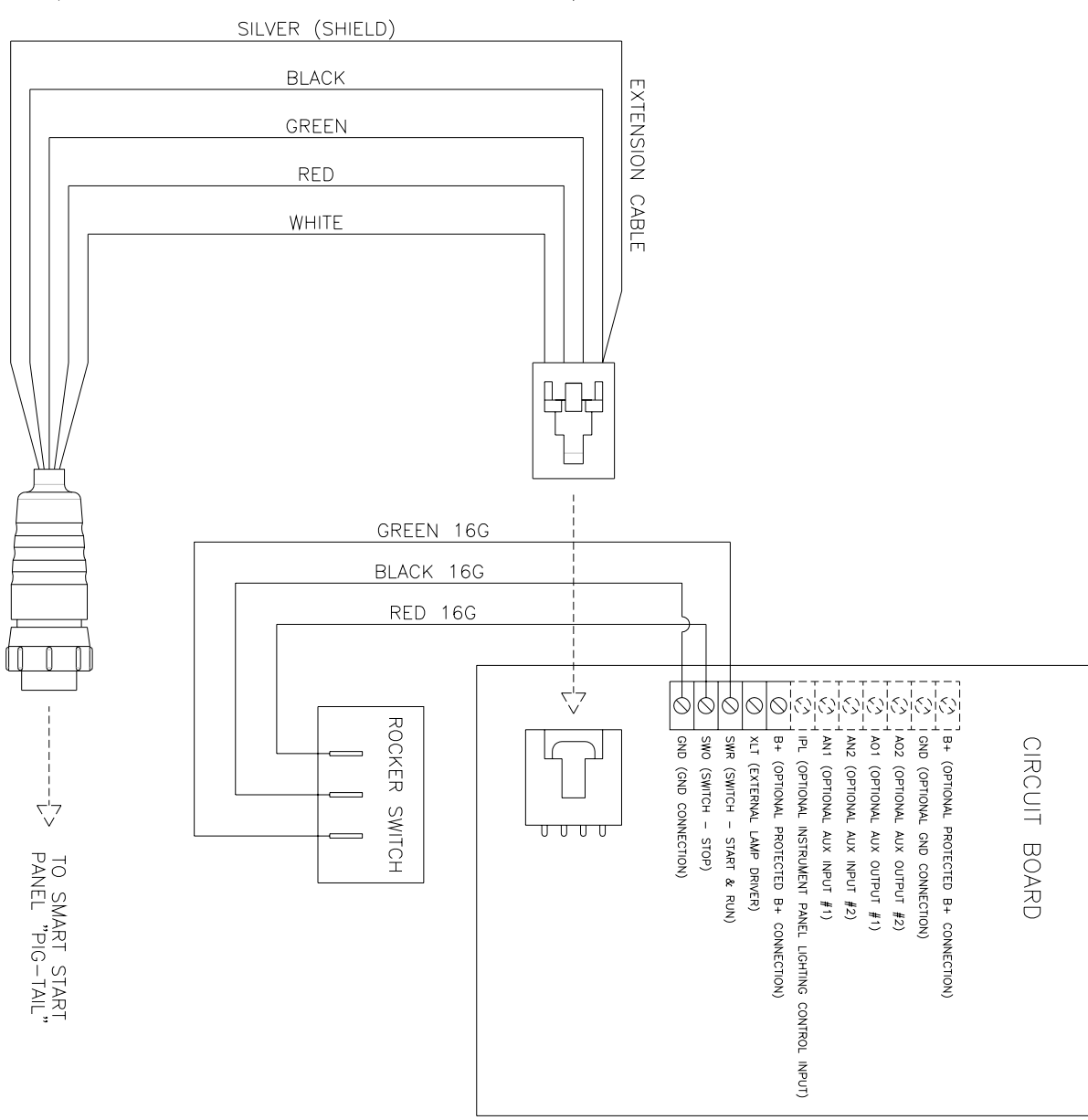
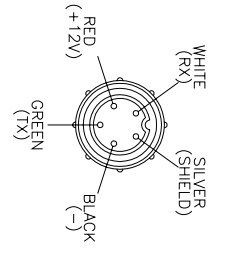

TO SMART START
PANEL "PIG-TAIL"

NO SCALE ACAD

This Document and all information contained in this document are confidential and proprietary to EPS. Unauthorized possession or use thereof is prohibited. This document, or any part hereof, or any information contained herein, may not be duplicated, reproduced, or disclosed to any person for any purpose except as specifically authorized in writing by EPS. By accepting this document, recipient agrees to comply with the foregoing and to return this document to EPS immediately upon request. Unpublished - all rights reserved under copyright laws.

ENGINE POWER SOURCE	220 Olympic Street, Charlotte, NC 28273 Phone: 704-553-7286 Fax: 704-588-9719	CAD BY	PSL	DATE	9/13/01	SHEET NUMBER	1 OF 1	UNSPECIFIED TOLERANCES ANGULAR.....1/2" FRACTION.....0.15 .XX.....0.10 .XXX.....0.05	
PART NUMBER	EPS1893	REVISION	B	DESCRIPTION	SCHEM, REM PANEL W/ ROCKER SW	MATERIAL	-		ADDITIVE FINISH

REV	DATE	REVISION	BY
A	-	RELEASED FOR PRODUCTION	-
B	11/11/03	CHANGED TO ROUND 5-PIN PLUG	PSL

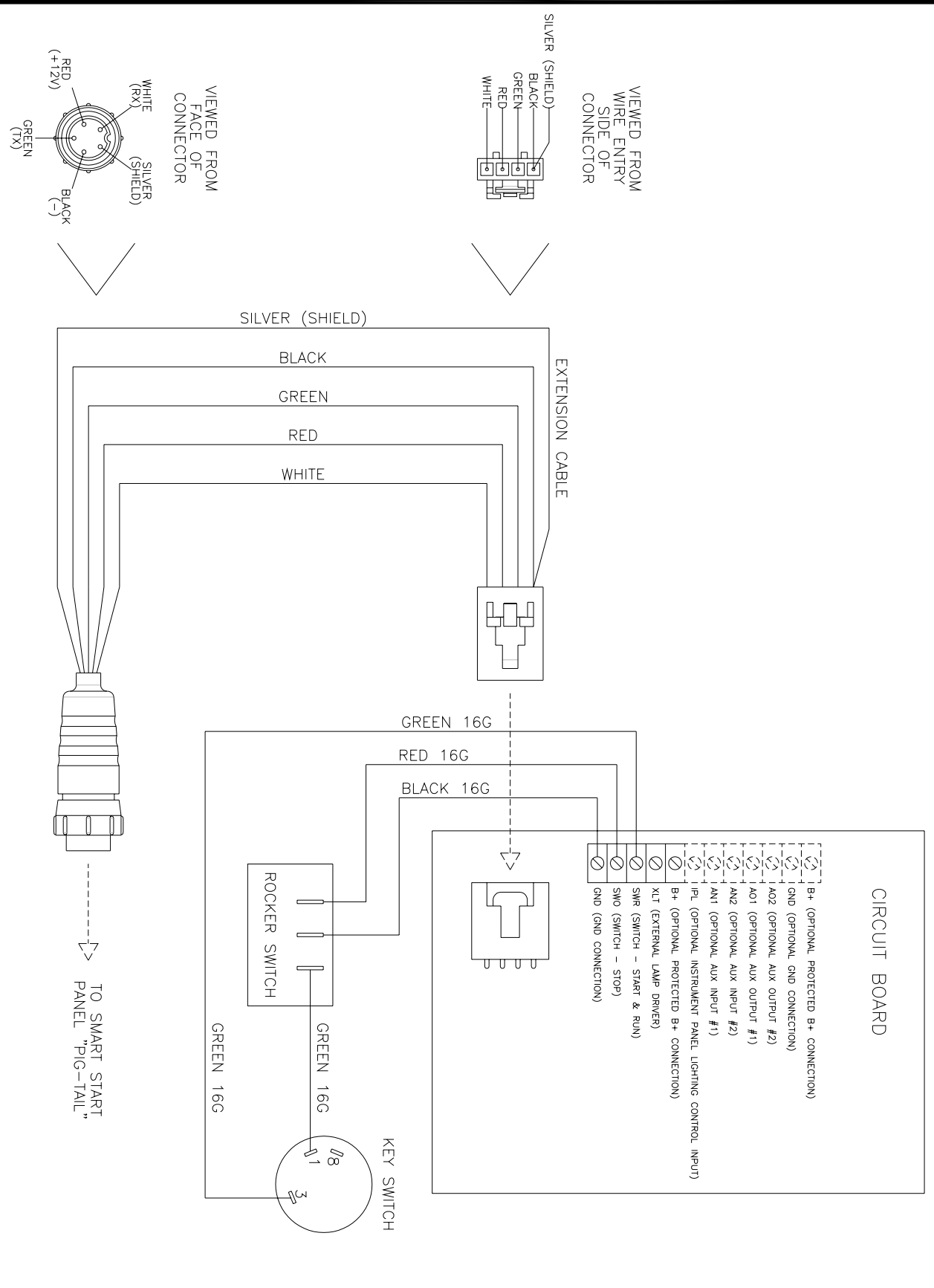

NO SCALE ACAD

This Document and all information contained in this document are confidential and proprietary to EPS. Unauthorized possession or use thereof is prohibited. This document, or any part hereof, or any information contained herein, may not be duplicated, reproduced, or disclosed to any person for any purpose except as specifically authorized in writing by EPS. By accepting this document, recipient agrees to comply with the foregoing and to return this document to EPS immediately upon request. Unpublished - all rights reserved under copyright laws.

EPS	ENGINE POWER SOURCE	220 Olympic Street, Charlotte, NC 28273 Phone: 704-553-7286 Fax: 704-588-9719	CAD BY PSL	DATE 9/20/01	SHEET NUMBER 1 OF 1	UNSPECIFIED TOLERANCES ANGULAR.....1/2" FRACTION.....015 .XX.....010 .XXX.....005
EPS1894	REVISION B	DESCRIPTION SCHEM, REM PANEL W/ KEY SW	MATERIAL -	ADDITIVE FINISH -		

***SMART
START
PARTS LIST***

REV	DATE	DESCRIPTION OF CHANGE	BY:
A	10-Nov-03	RELEASED FOR PRODUCTION	PSL

BILL OF MATERIALS

ITEM	QTY	DESCRIPTION	MANUF. NO.
1	1	BOTTOM COVER, SMART START M-B	EPS2018
2	1	CONTROL BOX, SMART START M-B	EPS2016
3	1	CONTROL COVER, REAR	EPS28-2
4	1	DECAL, SMART START M-B	EPS2018
5	1	ENGINE CONTROLLER, STANDARD COACH	EPS2102X
6	1	EPS LASER-PRINT NAMEPLATE	EPS1978
7	1	GROMMET	2277
8	1	HOUR METER	85000 SERIES
9	1	KEWSWITCH	90047-01
10	1	LOW WATER MODULE	LLI-120C-N-0-30

- 5 INSIDE BOX
- 8 INSIDE BOX

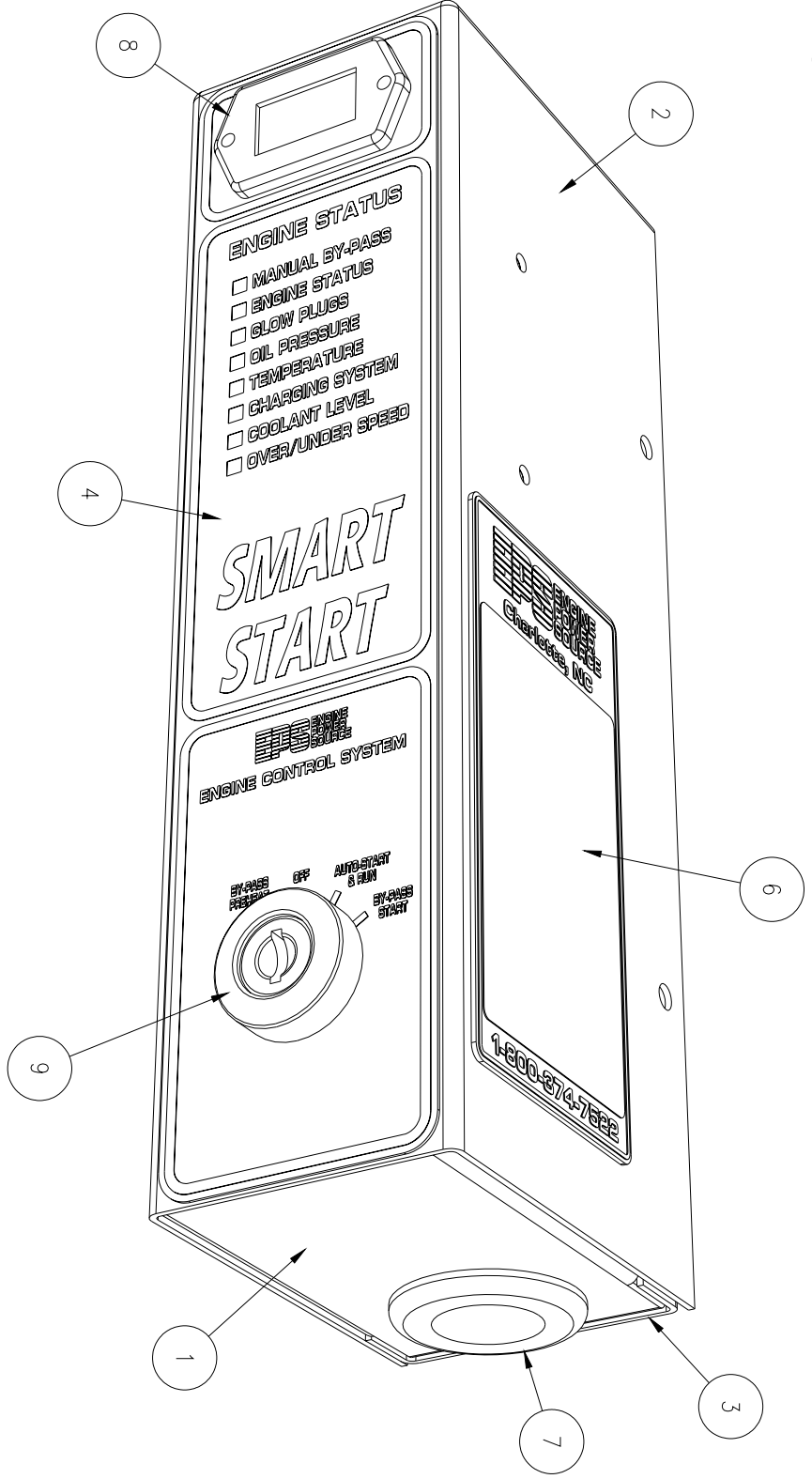

SCALE: 0.500

Pro/E

This Document and all information contained in this document are confidential and proprietary to EPS. Unauthorized possession or use thereof is prohibited. This document, or any part thereof, or any information contained herein, may be duplicated, reproduced, or disclosed in any form or by any means without the prior written consent of EPS. All rights reserved under copyright laws.

EPS	ENGINE POWER SOURCE	220 Olympic Street, Charlotte, NC 28273 Phone: 800-374-7522 Fax: 704-944-1918	CAD BY P.S.LaChapelle	DATE 10-Nov-03	SHEET NUMBER 1 of 1	UNSPECIFIED TOLERANCES BEND TOLS. .030 ANGULAR .1/2° FRACTION .015 .XX .010 .XXX .005
PART NUMBER EPS2015X	REVISION A	DESCRIPTION CONTROL BOX ASSY, SMART START	MATERIAL -	ADDITIVE FINISH -		

REV	DATE	DESCRIPTION OF CHANGE	BY:
A	04-Apr-01	RELEASED FOR PRODUCTION	PSI

BILL OF MATERIALS

ITEM	DESCRIPTION	MANUF. NO.	QTY
1	PANEL, DISPLAY TOGGLE	EPS1776	1
2	DECAL, DISPLAY TOGGLE	EPS1778	1
3	STD BUS GENSET DISPLAY ASSY	EPS1828X	1
4	SCREW, PAN HEAD MACHINE SLOTTED	6-32 X .50 LG	4
5	SCREW, FLAT HEAD MACHINE PHILLIPS	8-32 X 1/4 LG	4
6	TOGGLE SWITCH	V8D1500C-AZB00-000	1
7	BEZEL	VMS-01	1

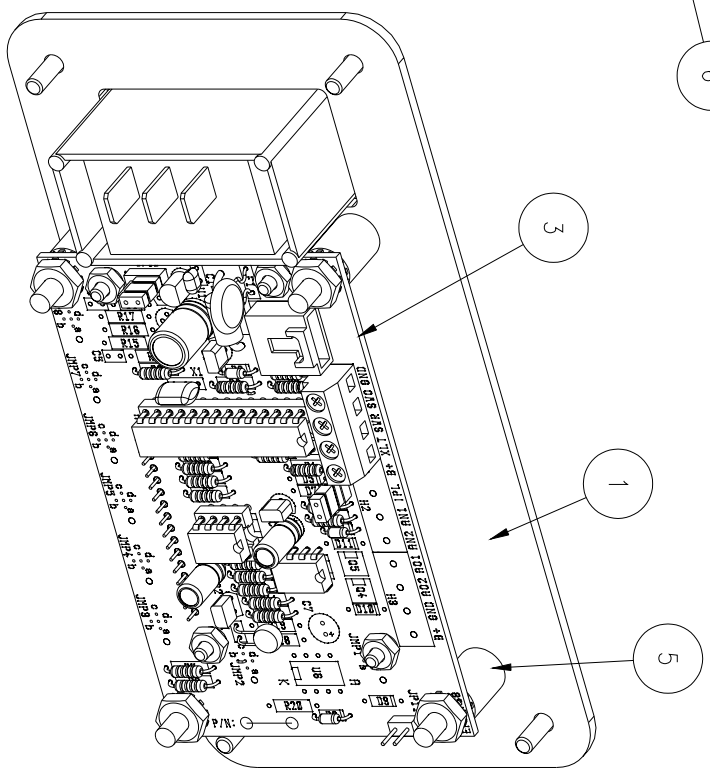
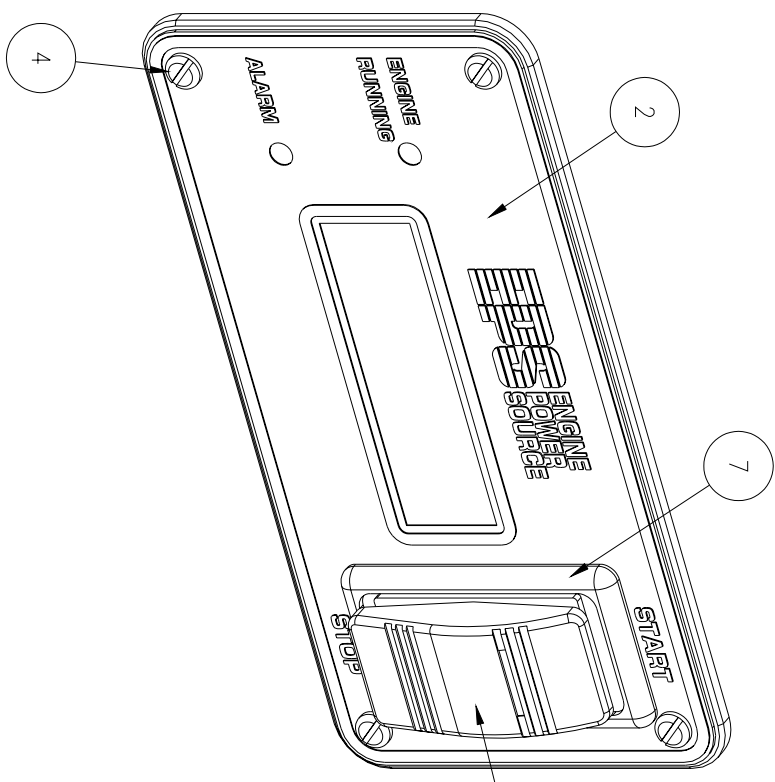

SEE EPS1781 DRILL TEMPLATE, REMOTE PANEL
FOR INSTALLATION DIMENSIONS

SCALE: 0.750 Pro/E

This Document and all information contained in this document are confidential and proprietary to EPS. Unauthorized possession or use thereof is prohibited. This document or any part hereof or any information contained herein, may not be duplicated, reproduced or disclosed to any person for any purpose except as specifically authorized in writing by EPS. By accepting this document, recipient agrees to comply with the foregoing and to return this document to EPS immediately upon request. Unpublished rights reserved under copyright laws.

EPS ENGINE POWER SOURCE PART NUMBER EPS1805X	220 Olympic Street, Charlotte, NC 28273 Phone: 800-374-7522 Fax: 704-944-1918	CAD BY P.S.LaChapelle	DATE 04-Apr-01	SHEET NUMBER 1 of 1	UNSPECIFIED TOLERANCES BEND TOLS. .030 ANGULAR .1/2 FRACTION .015 .XX .010 .XXX .005
	REVISION DESCRIPTION A REMOTE PANEL ASSY, TOGGLE	MATERIAL -	ADDITIVE FINISH -		

REV	DATE	DESCRIPTION OF CHANGE	BY:
A	04-Apr-01	RELEASED FOR PRODUCTION	PSL

BILL OF MATERIALS

ITEM	DESCRIPTION	MANUF. NO.	QTY
1	PANEL, DISPLAY KEY	EPS1776	1
2	DECAL, DISPLAY KEY	EPS1779	1
3	STD BUS GENSET DISPLAY ASSY	EPS1828X	1
4	SCREW, PAN HEAD MACHINE SLOTTED	6-32 X .50 LG	4
5	SCREW, FLAT HEAD MACHINE PHILLIPS	8-32 X 1/4 LG	4
6	KEY SWITCH	Y1011U2C203N0	1
7	ROCKER SWITCH	GRS-4013C-0001	1

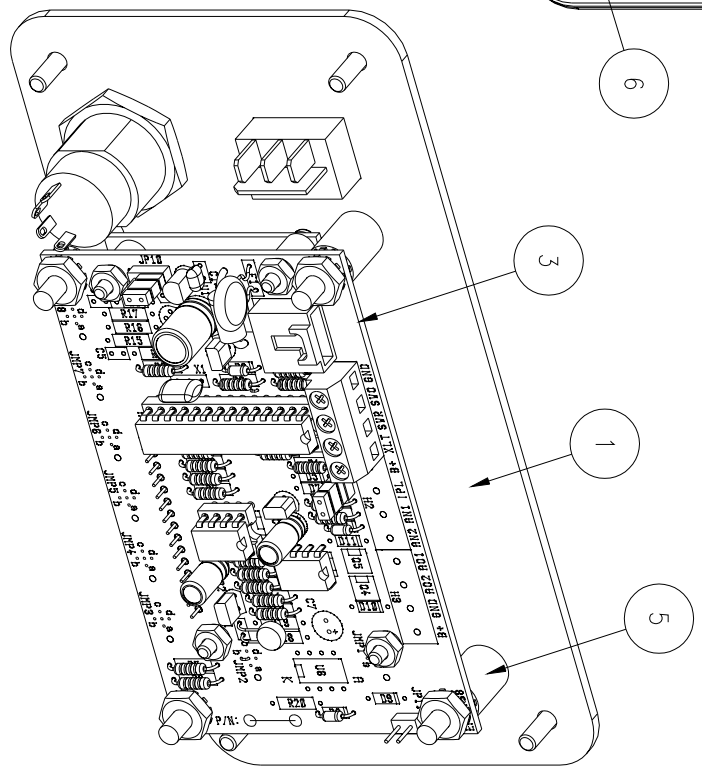
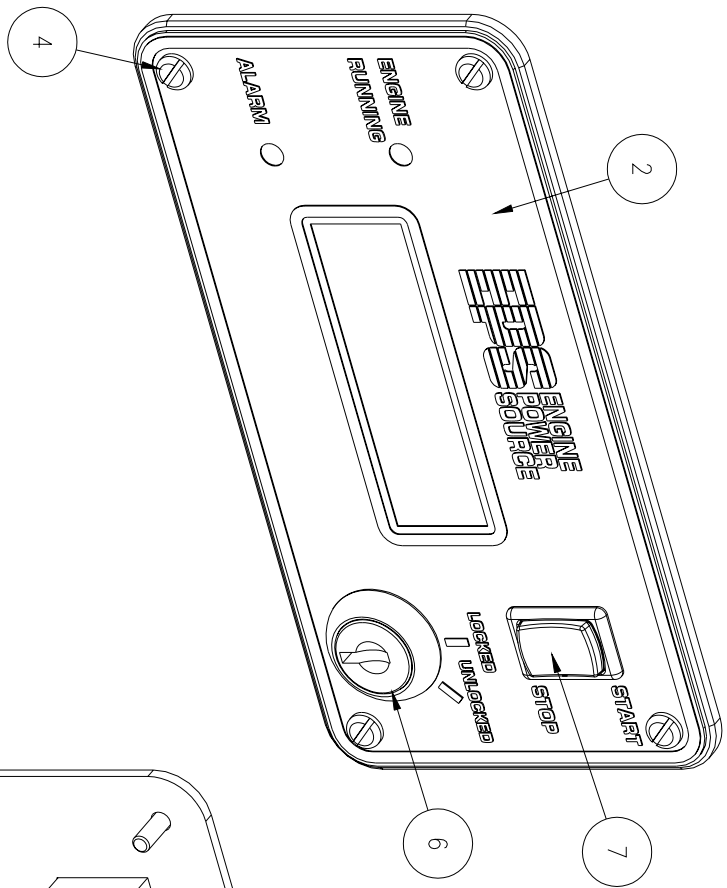

SEE EPS1781 DRILL TEMPLATE, REMOTE PANEL FOR INSTALLATION DIMENSIONS

SCALE: 0.750 Pro/E

This Document and all information contained in this document are confidential and proprietary to EPS. Unauthorized possession or use thereof is prohibited. This document, or any part hereof, or any information contained herein, may not be duplicated, reproduced, or disclosed to any person for any purpose except as specifically authorized in writing by EPS. By accepting this document, recipient agrees to comply with the foregoing and to return this document to EPS immediately upon request. Unpublished—all rights reserved under copyright laws.

EPS	ENGINE POWER SOURCE	220 Olympic Street, Charlotte, NC 28273 Phone: 800-374-7522 Fax: 704-944-1918	CAD BY P.S.LaChapelle	DATE 04-Apr-01	SHEET NUMBER 1 of 1	UNSPECIFIED TOLERANCES BEND TOLS. .030 ANGULAR .1/2" FRACTION .015 .XX .010 .XXX .005
PART NUMBER EPS1806X	REVISION A	DESCRIPTION REMOTE PANEL ASSY, KEY	MATERIAL	ADDITIVE FINISH		

REV	DATE	DESCRIPTION OF CHANGE	BY:
A	01-Feb-01	RELEASED FOR PRODUCTION	PSL

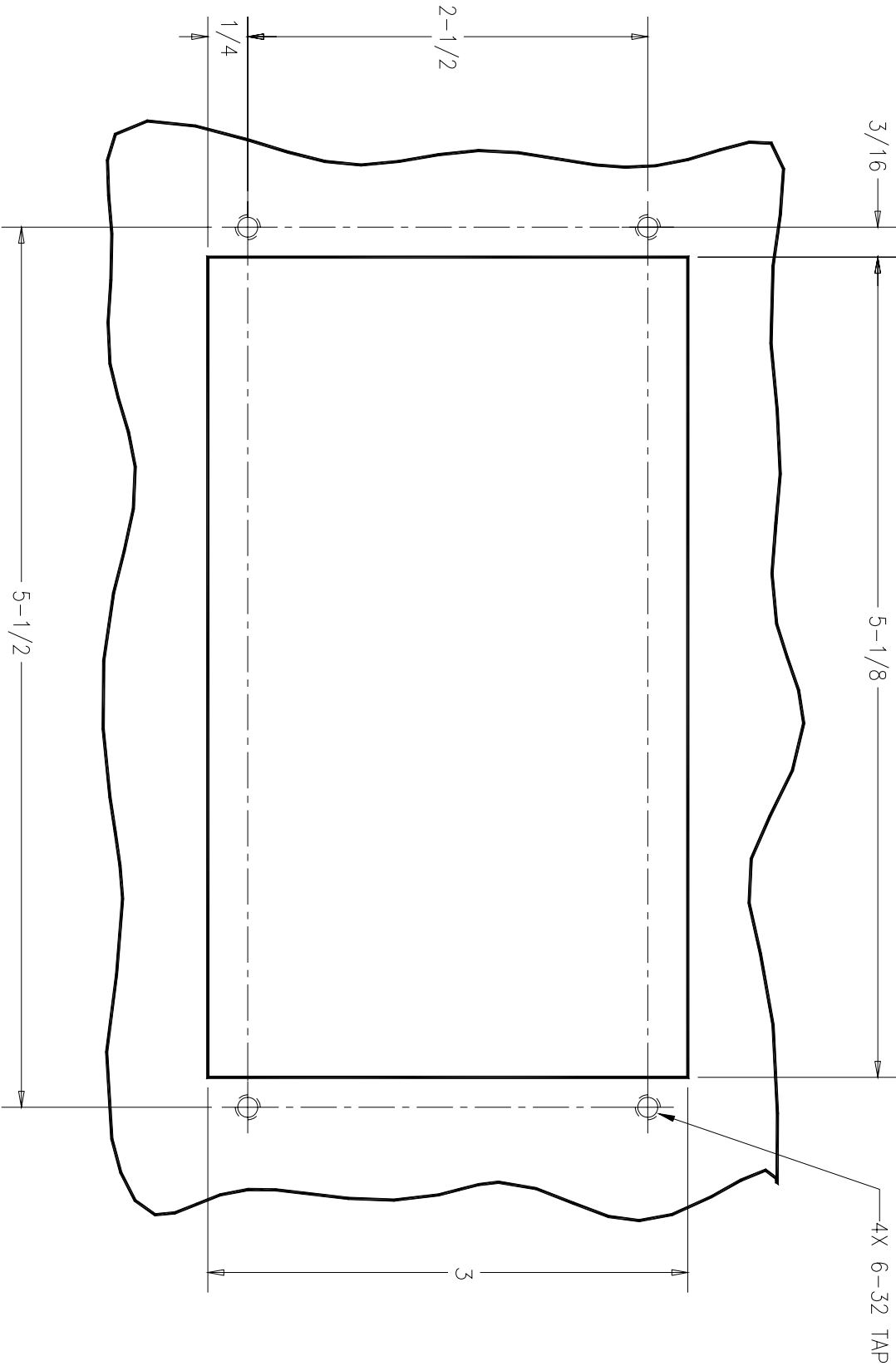

SCALE: 1.000

Pro/E

This Document and all information contained in this document are confidential and proprietary to EPS. Unauthorised possession or use thereof is prohibited. This document, or any part hereof, or any information contained herein, may not be duplicated, reproduced, or disclosed to any person for any purpose except as specifically authorized in writing by EPS. By accepting this document, recipient agrees to comply with the foregoing and to return this document to EPS immediately upon request. Unpublished - all rights reserved under copyright laws.

EPS ENGINE POWER SOURCE	220 Olympic Street, Charlotte, NC 28273 Phone: 800-374-7522 Fax: 704-944-1918		CAD BY P.S.LaChapelle	DATE 01-Feb-01	SHEET NUMBER 1 of 1	UNSPECIFIED TOLERANCES BEND TOLS. .030 ANGULAR .1/2 FRACTION .015 .XX .010 .XXX .005
	PART NUMBER EPS1781	REVISION A	DESCRIPTION DRILL TEMPLATE, REMOTE PANEL	MATERIAL -	ADDITIVE FINISH NONE	